



S75-76

Low Pressure Spin-On Filter Assemblies

Hy-Pro low pressure S series filters are designed for installation on the return line to remove contaminant ingested or generated by the system. Functions include off-line filtration (kidney loop or filter cart) and some suction applications.

Ideal for automotive manufacturing and assembly machine tools, mobile applications such as waste haulers and transit, filter carts and filter panels, and power unit return line/suction.

Max Operating Pressure: 200 psi (13.8 bar)



Media matters.

DFE rated filter elements stay true to efficiency ratings and ensure the highest level of particulate capture and retention capabilities. And with media options down to $\beta_{2.5[\text{C}]} \geq 1000$ or $\beta_{5[\text{C}]} \geq 1000 +$ water removal, you can be sure contamination stays exactly where you want it: out of your fluid.



Multiple configurations.

With a variety of connection types and sizes, mounting options, pressure indicators, media options and sample ports, there is a Spin-On assembly to meet the needs for almost any application.



Double duty.

S75D assemblies pack double the punch using two Hy-Pro Spin-Ons in a parallel flow arrangement. Ideal for high flow or high viscosity applications, these assemblies offer unmatched filtration surface area in a compact size.



Filter Sizing Guidelines

Filter Assembly Sizing Guidelines

Effective filter sizing requires consideration of flow rate, viscosity (operating and cold start), fluid type and degree of filtration. When properly sized, bypass during cold start can be avoided/minimized and optimum element efficiency and life achieved. The filter assembly differential pressure values provided for sizing differ for each media code, and assume 32 cSt (150 SUS) viscosity and 0.86 fluid specific gravity. Use the following steps to calculate clean element assembly pressure drop.

Sizing recommendations to optimize performance and permit future flexibility

- To avoid or minimize bypass during cold start the actual assembly clean ΔP calculation should be repeated for start-up conditions if cold starts are frequent.
- Actual assembly clean ΔP should not exceed 10% of bypass ΔP gauge/indicator set point at normal operating viscosity.
- If suitable assembly size is approaching the upper limit of the recommended flow rate at the desired degree of filtration consider increasing the assembly to the next larger size if a finer degree of filtration might be preferred in the future. This practice allows the future flexibility to enhance fluid cleanliness without compromising clean ΔP or filter element life.
- Once a suitable filter assembly size is determined consider increasing the assembly to the next larger size to optimize filter element life and avoid bypass during cold start.
- When using water glycol or other specified synthetics, we recommend increasing the filter assembly by 1~2 sizes.

Step 1: Calculate ΔP coefficient for actual viscosity

Using Saybolt Universal Seconds (SUS)

$$\Delta P \text{ Coefficient} = \frac{\text{Actual Operating Viscosity}^1 \text{ (SUS)}}{150} \times \frac{\text{Actual Specific Gravity}}{0.86}$$

Using Centistokes (cSt)

$$\Delta P \text{ Coefficient} = \frac{\text{Actual Operating Viscosity}^1 \text{ (cSt)}}{32} \times \frac{\text{Actual Specific Gravity}}{0.86}$$

Step 2: Calculate actual clean filter assembly ΔP at both operating and cold start viscosity

$$\text{Actual Assembly Clean } \Delta P = \text{Flow Rate} \times \Delta P \text{ Coefficient (from Step 1)} \times \text{Assembly } \Delta P \text{ Factor (from sizing table)}$$

Filter Sizing¹

Filter assembly clean element ΔP after actual viscosity correction should not exceed 10% of filter assembly bypass setting. See above for filter assembly sizing guidelines & examples. For applications with extreme cold start condition contact Hy-Pro for sizing recommendations.

ΔP Factors¹

Series	Length	Units	Media						
			1M	3M	6M	12M	16M	25M	**W
S75	L4	psid/gpm	0.332	0.280	0.217	0.195	0.190	0.183	0.033
		bard/lpm	0.006	0.005	0.004	0.004	0.003	0.003	0.001
	L8	psid/gpm	0.183	0.155	0.120	0.107	0.105	0.101	0.018
		bard/lpm	0.003	0.003	0.002	0.002	0.002	0.002	0.000
S75D	L4	psid/gpm	0.166	0.140	0.108	0.097	0.095	0.092	0.017
		bard/lpm	0.003	0.003	0.002	0.002	0.002	0.002	0.000
	L8	psid/gpm	0.092	0.077	0.060	0.054	0.053	0.051	0.009
		bard/lpm	0.002	0.001	0.001	0.001	0.001	0.001	0.000
S76	L4	psid/gpm	0.573	0.484	0.375	0.336	0.329	0.317	0.057
		bard/lpm	0.010	0.009	0.007	0.006	0.006	0.006	0.001
	L8	psid/gpm	0.310	0.261	0.203	0.182	0.178	0.171	0.031
		bard/lpm	0.006	0.005	0.004	0.003	0.003	0.003	0.001

Series	Length	Units	Media						
			3A	6A	12A	25A	3C	10C	25C
S75	L4	psid/gpm	0.311	0.241	0.216	0.204	0.448	0.292	0.284
		bard/lpm	0.006	0.004	0.004	0.004	0.008	0.005	0.005
	L8	psid/gpm	0.172	0.133	0.119	0.113	0.247	0.161	0.157
		bard/lpm	0.003	0.002	0.002	0.002	0.005	0.003	0.003
S75D	L4	psid/gpm	0.156	0.121	0.108	0.102	0.224	0.146	0.142
		bard/lpm	0.003	0.002	0.002	0.002	0.004	0.003	0.003
	L8	psid/gpm	0.086	0.067	0.060	0.056	0.124	0.081	0.078
		bard/lpm	0.002	0.001	0.001	0.001	0.002	0.001	0.001
S76	L4	psid/gpm	0.533	0.413	0.370	0.349	0.774	0.505	0.491
		bard/lpm	0.010	0.008	0.007	0.006	0.014	0.009	0.009
	L8	psid/gpm	0.288	0.223	0.200	0.188	0.418	0.273	0.265
		bard/lpm	0.005	0.004	0.004	0.003	0.008	0.005	0.005

¹Max flow rates and ΔP factors assume u = 150 SUS, 32 cSt. See filter assembly sizing guideline for viscosity conversion formula.

S75-76 Specifications

Installation Drawing

S75 Installation Drawing

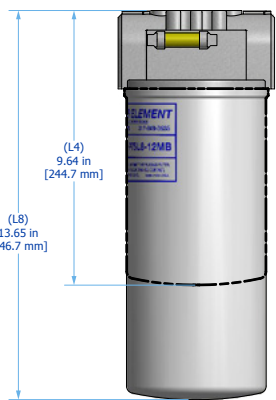
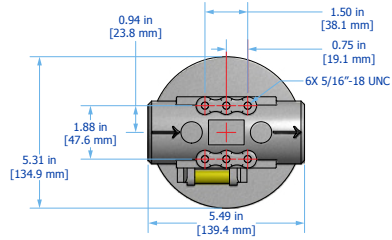

S75D Installation Drawing

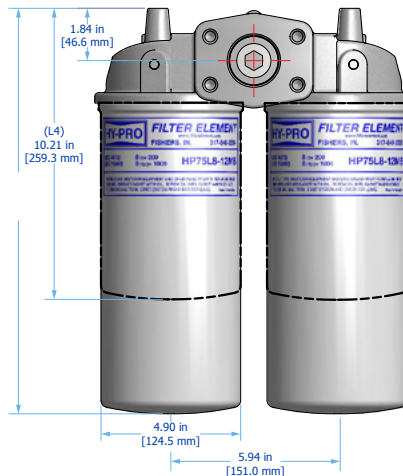
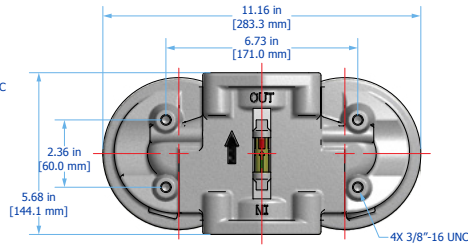

S76 Installation Drawing

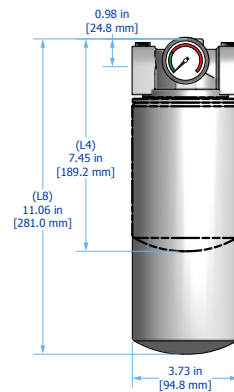
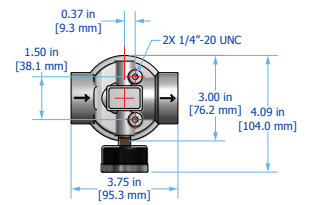

Operating Temperature

Fluid Temperature
30°F to 225°F
(0°C to 105°C)

Ambient Temperature
-4°F to 140°F
(-20C to 60C)

Operating Pressure

200 psi (13.8 bar) max

ΔP Indicator Trigger

22 psi (1.5 bar) or 44 psi (3.0 bar)

Element Collapse

100 psid (6.9 bard) max

Materials of Construction

Head
Cast aluminum

Can
Stamped steel

Element Bypass Valve
Nylon

Element End Caps
Zinc or Tin coated carbon steel

Media Description

M
G8 Dualglass, our latest generation of DFE rated, high performance glass media for all hydraulic & lubrication fluids. $\beta_{x_{C1}} \geq 1000$ ($\beta_x \geq 200$)

A
G8 Dualglass high performance media combined with water removal scrim. $\beta_{x_{C1}} \geq 1000$ ($\beta_x \geq 200$)

W
Stainless steel wire mesh media $\beta_{x_{C1}} \geq 2$ ($\beta_x \geq 2$)

Replacement Elements

To determine replacement elements, use corresponding codes from your assembly part number:

Series

S75
S75D
S76

Filter Element Part Number

HP75L[Length Code] - [Media Selection Code] [Seal Code]
HP75L[Length Code] - [Media Selection Code] [Seal Code]
HP76L[Length Code] - [Media Selection Code] [Seal Code]

Example

HP75L4-25MV
HP75L8-12AB
HP76L8-3MB

Fluid Compatibility

Petroleum and mineral based fluids (standard). For polyol ester, phosphate ester, and other specified synthetic fluids use fluorocarbon seal option or contact factory.

S75-76 Part Number Builder



Series	Series	Max Flow Rate
75	HP75 Series Filter Element, single head	50 gpm (189 lpm) ¹
75D	HP75 Series Filter Elements, double head	100 gpm (379 lpm) ¹
76	HP76 Series Filter Element, single head	30 gpm (111 lpm) ¹

Connection	S75	S75D	S76
B20	1¼" BSPT	F32 2" Code 61 flange	B12 ¾" BSPT
N20	1¼" NPT	G20 1¼" BSPP	N12 ¾" NPT
S20	1¼" SAE, 1½" - 12	G24 1½" BSPP	N16 1" NPT
		N24 1½" NPT	S8 ½" SAE, ¾" - 16
		S24 1½" SAE, 1¾" - 12	S12 ¾" SAE, 1½" - 12

Element Length	4	8
	4" (10 cm) nominal length filter element	8" (20 cm) nominal length filter element

Bypass	02 ²	2	3 ³	X
	3 psid (0.2 bard)	25 psid (1.7 bard)	50 psid (3.4 bard)	No bypass

ΔP Indicator	DX	E	G ⁴	V ⁵	X
	Electrical pressure switch (DIN Connector)	Electrical pressure switch 3-Wire	Visual pressure gauge	Visual ΔP indicator (sliding green to red)	No indicator (port plugged)

Special Options	S
	Oil sampling port on filter head

Media Selection	G8 Dualglass	G8 Dualglass+water removal	Cellulose	Stainless wire mesh
1M	β _{2.5} (_c) ≥ 1000, β ₁ ≥ 200	3A β ₅ (_c) ≥ 1000, β ₃ ≥ 200	3C β ₅ (_c) ≥ 5, β ₃ ≥ 5	25W 25μ nominal
3M	β ₅ (_c) ≥ 1000, β ₃ ≥ 200	6A β ₇ (_c) ≥ 1000, β ₆ ≥ 200	10C β ₁₂ (_c) ≥ 5, β ₁₂ ≥ 5	40W 40μ nominal
6M	β ₇ (_c) ≥ 1000, β ₆ ≥ 200	12A β ₁₂ (_c) ≥ 1000, β ₁₂ ≥ 200	25C β ₂₅ (_c) ≥ 5, β ₂₅ ≥ 5	74W 74μ nominal
12M	β ₁₂ (_c) ≥ 1000, β ₁₂ ≥ 200	25A β ₂₂ (_c) ≥ 1000, β ₂₅ ≥ 200		149W 149μ nominal
16M	β ₁₇ (_c) ≥ 1000, β ₁₇ ≥ 200			
25M	β ₂₂ (_c) ≥ 1000, β ₂₅ ≥ 200			
40M	β ₃₅ (_c) ≥ 1000, β ₄₀ ≥ 200			

Seals	B	V	E-WS ⁶
	Nitrile (Buna)	Fluorocarbon	EPR seals + stainless steel support mesh

¹Maximum recommended flow rate based on velocity through port and internal flow path. Consult sizing guidelines or consult factory for sizing based on flow rate, viscosity, temperature, filter media selection.
²Only available with "G" indicator option, supplied as vacuum gauge. Contact factory for other options or pressure applications.
³Only available with S75/S75D Series options.
⁴Select (2) G - "GG" - for reading differential pressure / vacuum between the two gages.
⁵Only available with S75/S75D, Bypass Option "2" - 25 psid (1.7 bard).
⁶Only available with filter element HP75L8-3M

